

## **How to build your own practice weapons.**

As part of our tradition, Japan Ways teaches kata and practice of the traditional Okinawan weapons – bo (staff), kama (sickle), tonfa, and sai. While all of these weapons are commercially available for purchase, you may prefer to build your own, which for the most part, is inexpensive and easy to do. Here's a basic guide on how to build your own practice weapons.

**Bo:** This one is easy. Home Depot and Lowes both carry 1" dowels in 6 ft and 8ft lengths. The dowels are pine, which is fairly light but otherwise sturdy. Just be sure that the dowel you select is straight (not as easy as you'd think). The easiest way to check straightness is to lay it on the floor and roll it – if any part of the dowel lifts off the ground, it's not straight. You're not likely to get one that's perfectly straight (that's ok), but you probably don't want one that resembles an old tree root either. Once you've selected your staff you'll need to cut it to the proper height. In general, a bo should extend just past the top of your head – but if you're still growing, feel free to cut it a bit longer to give you some growing room. After that you'll need to sand it down. Get some sand paper (150 grit works fine, but you can go finer if you want a smoother finish), and start sanding – don't forget to sand the ends. This will get rid of any splinters and rough spots and generally makes for a nice looking bo. From there you can paint it, stain it, wrap it in tape, just leave it be – what ever you feel like.

**Kama and Tonfa:** A simple practice tonfa and kama are also really easy to make. Once again, we're headed to the local home improvement store, but this time to the plumbing isle. To make a pair of kama or a pair of tonfa, you are going to need about 10 feet of 1" or 1½ " PVC pipe, 2 tees (make sure they match the size of pipe you selected), 6 end caps, and some PVC glue. See the attached sketch for guidance on dimensions. Basically, cut the pipe to the required size, slop some glue on the ends and stick the fittings on. Note that it is really important that you actually glue it together – we don't want kama parts flying around the dojo during practice! Once everything is glued together, you can spray paint it, wrap it in tape or leave it as the default PVC white – whatever you prefer. If you want, you can also build these out of iron pipe. This will be more expensive and you'll be stuck with standard pipe lengths (iron pipe has threaded ends and can't be cut and glued like PVC), but they will be much heavier and will help in wrist and forearm strength development.

**Sai:** Unfortunately, unless you have access to a foundry or blacksmith, there's no way to make up a set of practice sai. But we'll be happy to order a pair for you.

One final note: although these practice weapons will work fine for practice, they will not have the weight or balance of a properly constructed Okinawan weapon (and won't look quite as cool either). Japan Ways has access to several vendors that can supply a wide range of traditional weapons, so if you'd like to order the real thing, please talk to Sensei Wong, or send us an email!

# JAPAN WAYS TRADITIONAL KARATE

## Build Your Own Practice Weapons

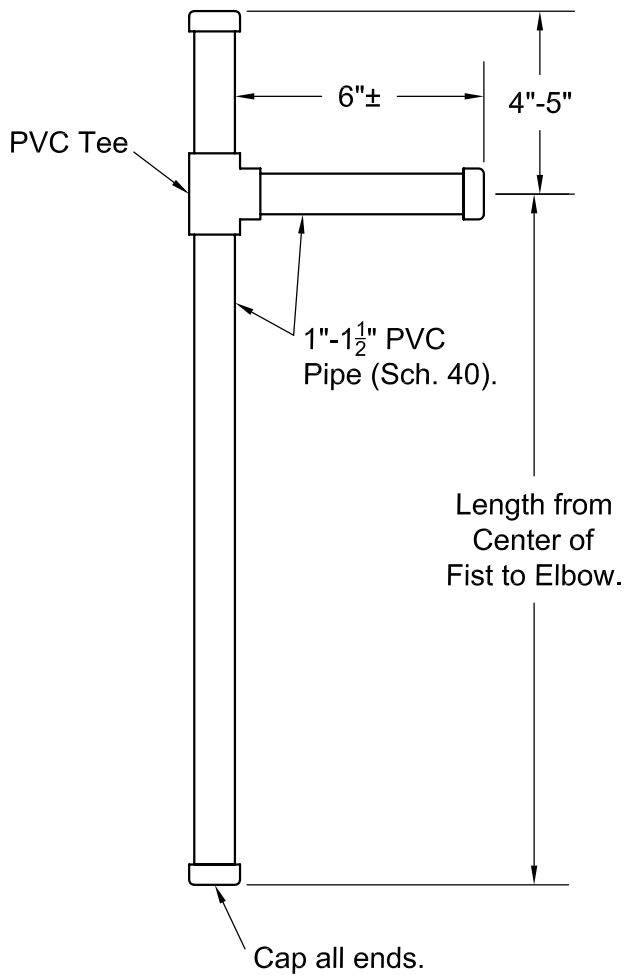

Practice Tonfa

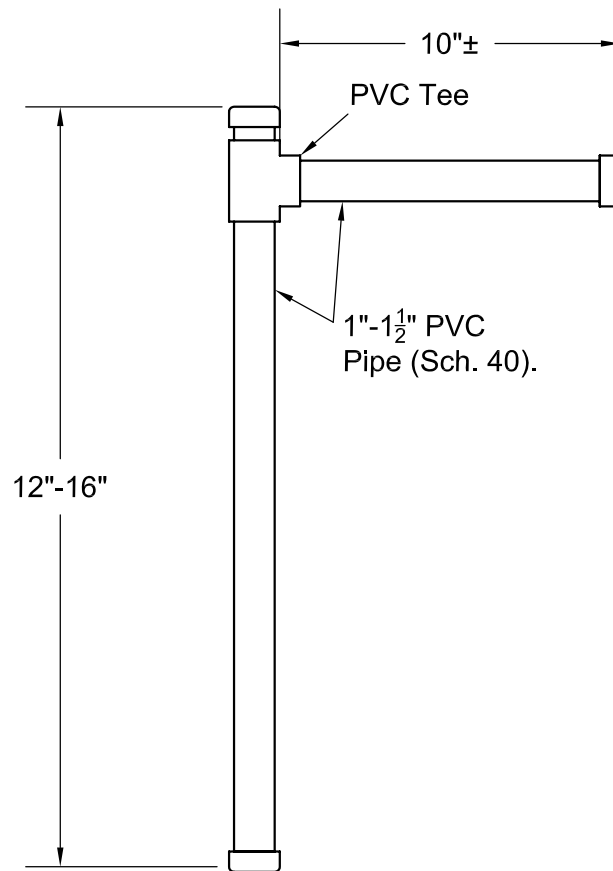

Practice Kama

Be sure to glue everything together!